

CZT2000

**SURFACE MOUNT
NPN EXTREMELY HIGH VOLTAGE
SILICON DARLINGTON TRANSISTOR**

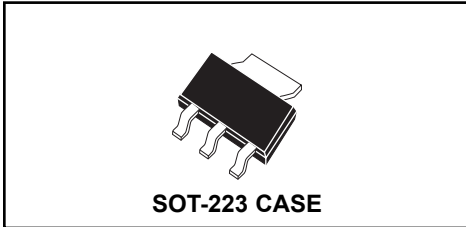

CentralTM

Semiconductor Corp.

DESCRIPTION:

The CENTRAL SEMICONDUCTOR CZT2000 type is an NPN Epitaxial Planar Silicon darlington transistor manufactured in an epoxy molded surface mount package, designed for applications requiring extremely high voltages and high gain capability.

MARKING CODE: FULL PART NUMBER

MAXIMUM RATINGS: ($T_A=25^\circ\text{C}$)

	SYMBOL		UNITS
Collector-Base Voltage	V_{CBO}	200	V
Collector-Emitter Voltage	V_{CES}	200	V
Emitter-Base Voltage	V_{EBO}	10	V
Collector Current	I_C	600	mA
Power Dissipation	P_D	2.0	W
Operating and Storage			
Junction Temperature	T_J, T_{stg}	-65 to +150	$^\circ\text{C}$
Thermal Resistance	θ_{JA}	62.5	$^\circ\text{C/W}$

ELECTRICAL CHARACTERISTICS: ($T_A=25^\circ\text{C}$ unless otherwise noted)

SYMBOL	TEST CONDITIONS	MIN	MAX	UNITS
I_{CBO}	$V_{CB}=180\text{V}$		500	nA
I_{EBO}	$V_{BE}=10\text{V}$		100	nA
BV_{CES}	$I_C=1.0\text{mA}$	200		V
$V_{CE(SAT)}$	$I_C=20\text{mA}, I_B=25\mu\text{A}$		0.9	V
$V_{CE(SAT)}$	$I_C=80\text{mA}, I_B=40\mu\text{A}$		1.1	V
$V_{CE(SAT)}$	$I_C=160\text{mA}, I_B=100\mu\text{A}$		1.2	V
$V_{BE(ON)}$	$V_{CE}=5.0\text{V}, I_C=160\text{mA}$		2.0	V
h_{FE}	$V_{CE}=5.0\text{V}, I_C=100\mu\text{A}$	3000		
h_{FE}	$V_{CE}=5.0\text{V}, I_C=10\text{mA}$	3000		
h_{FE}	$V_{CE}=5.0\text{V}, I_C=160\text{mA}$	3000		

**SURFACE MOUNT
NPN EXTREMELY HIGH VOLTAGE
SILICON DARLINGTON TRANSISTOR**

SOT-223 CASE - MECHANICAL OUTLINE

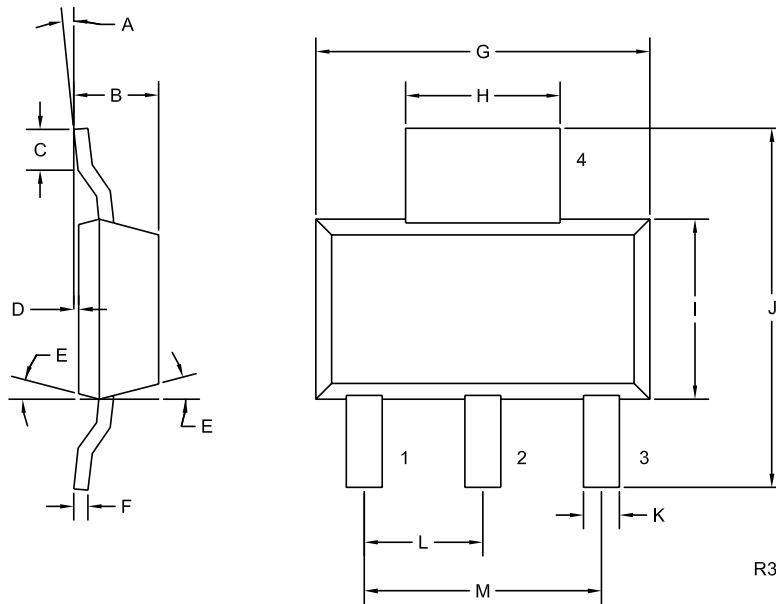

LEAD CODE:

- 1) BASE
- 2) COLLECTOR
- 3) EMITTER
- 4) COLLECTOR

MARKING CODE:

FULL PART NUMBER

SYMBOL	DIMENSIONS			
	INCHES		MILLIMETERS	
	MIN	MAX	MIN	MAX
A	0°	10°	0°	10°
B	0.059	0.071	1.50	1.80
C	0.018	---	0.45	---
D	0.000	0.004	0.00	0.10
E	15°		15°	
F	0.009	0.014	0.23	0.35
G	0.248	0.264	6.30	6.70
H	0.114	0.122	2.90	3.10
I	0.130	0.146	3.30	3.70
J	0.264	0.287	6.70	7.30
K	0.024	0.033	0.60	0.85
L	0.091		2.30	
M	0.181		4.60	

SOT-223 (REV: R3)